

Demo-Version

Installation

Install the demo version on your hard disk. If you like the program, you do not need to delete it. The main program will install its files into the same directories. It is also easy to remove the demo version if you want to (see 'notes on installation' below).

All the program functions of the regular version are available. The numerical input is limited, however.

The demo version only accepts the following values:

powers of ten of 0, 1, 2 and 5

constants: [30, 40, 45, 60, 90, 120, 180, $\sqrt{2}$, $\sqrt{0.5}$]

for example:

10, 0.2, 5kohm, 2mH, 100L, 60°, 1.414, ...

The demo version includes a simple design example. The exercise guides you through the program. You can follow the exercise partly or all of the way through. Either way, you will gain an impression of how AkAbak works.

In the demo version, the AkAbak help function will serve as the instructions for use. Try out also the other program functions (Help menu or F1 for context-sensitive help).

The installation program 'Install.exe' runs completely automatically. It creates a directory structure, copies the files onto the hard disk, decompresses them if necessary and installs the start icons in the Windows start menu. You can re-install or update at any time into the same directory structure. File created by your own are save, but all others will be over-written. The desktop files containing the current diagrams are erased. Save them temporarily into another folder.

- Windows™ 3.1, 95, NT operating system and an Intel® 80386 type processor (or higher or compatible).
- A numerical coprocessor (Intel® 80387) considerably speeds up calculations, but is not absolutely necessary. The program runs best on a computer with an Intel® 80486DX processor (or higher or compatible), in which the numerical coprocessor is already integrated.
- The video configuration should conform to the VGA (or higher) standard. The outputs are in color. Gray-scale-type monitors (LCD etc.) may not reproduce all the details satisfactorily. You can adjust the colors etc. in the 'File/ Preferences/ CRT Diagram Style' menu.
- The print out is on any A4 printer available in Windows™ 3.1 or 95.
- For the installation you need a 3½' high-density (HD) disk drive.

Starting the installation program

Insert diskette 1 into the disk drive. There are two ways of starting the installation program:

Using the Windows file manager

Open the file manager and change to the disk drive. Using the mouse, double click on `Install.exe` on the right-hand side of the list.

Using the Windows desktop

In Win3 'File/ Execute...' menu or in Win95 'Start/Execute...' enter the following: A:\Install.exe. You can also use the 'browse' button. Start the installation program using the OK button.

Select the target drive and directory

After you have started `Install.exe`, the dialog 'Installation of AkAbak' appears. Decide which drive you want to install AkAbak on. It does not take up more than 5 megabytes of space on your hard disk. In the input box, enter the drive and directory name in which you want to install the program. If the directory does not exist, one will be created. The format must conform to the DOS operating system: Drive:\Directory, for example: C:\AkAbak

Starting the installation

Click on the 'Installation' button. The installation starts. At some stage you will be prompted to insert the second diskette. When you have exchanged the diskette, press on the OK button and the installation continues. Finally, two start icons are installed in the program manager. At first, the start items are located in their own program group. You can of course move or copy them into a different group and then delete the AkAbak program group. The first icon starts the AkAbak program and the second starts the Abakus equation calculator.

Directory structure.

After the installation, you have the following directory structure on your hard disk.

...	\AkAbak	
	\Formula	files with equations of the Abakus program
	\Import	files for importing
	\MeasRad	Def_MeasRadiator files
	\Scripts	
	\Examples	example scripts
	\Project1	scripts of your first project
	\zProgram	program files

The `Scripts` sub-directory is located in the `Project1` directory. It is empty and you should regard it as a suggestion.. You can, of course, change the name if you want. With each new large project it is useful to install a new directory under `Scripts`. Use the Windows file manager for this. This file structure is not absolutely essential, but it has been found to be practical.

That concludes the installation.

Terminating the installation

The left-hand button 'terminate' immediately terminates the installation process.

If you accidentally click on this button using the mouse or press Esc, you just have to start the installation again from the beginning. Close the dialog by clicking on the 'terminate' button again or press Esc and insert diskette 1 in the drive again. You do not need to delete anything on the hard disk.

Removing the AkAbak program

All the files forming part of AkAbak are located in the installed directories. There are no hidden entries in the Windows directories or in the initialization file `win.ini`. Open the Windows file manager and activate the main AkAbak directory. The press the Del key.

First steps with the Script Editor

In AkAbak, the data for the simulation are entered via the script. The script is a text that describes the data of the component to be simulated. AkAbak displays the script in a window in which the text can be entered and edited. This window is said to work as a text editor. You can save the text and subsequently load it again from the hard disk and print it. If you are used to working with a text editor, you will feel completely at home. Of course, the AkAbak editor does not offer all the features of a full word processor, but only the functions necessary for editing the data. When you have entered the data, you can start the simulation at once. AkAbak interprets the script in the active window, since it is possible to work with several editors simultaneously. If an error occurs, a message is issued, otherwise the diagram for the desired simulation is generated.

A practical example follows to illustrate some functions of the editor. First create a new script: 'File/New...' menu

You are presented with an empty window. The title bar gives a default file name 'Script1.aks', which you should replace with a name of your own choice when you save the script.

The empty space can be filled with text. Type something. Using Backspace (←), delete the text again. Delete erases characters under the cursor. Enter (↵, Return) forces a new line. You can use the cursor keys ↑↓ to move back and forth and up and down in the text. Pressing the cursor keys with the control key (Ctrl) held down increases the cursor travel distance. Try this out...

It is important to know how to operate the so-called Clipboard. The Clipboard can be used to store Windows information, such as text and graphics, temporarily and to insert it again, in a different program if necessary. It is used in a similar way in all Windows programs. AkAbak makes heavy use of it.

To learn how to use the clipboard, type a few words. You copy this text into the clipboard by first marking it. Press the Shift key ↑ together with one of the cursor keys (the cursor keys Home, End, PgUp, PgDn, etc. also work). The control key remains active, or you can use the mouse for marking. Press the left-hand mouse key and keep it pressed. The text over which you move the mouse cursor is marked.

Now you have marked the text. The commands related to the clipboard are in all Windows programs in the 'Edit' menu. If you open this menu, you see the commands on the left-hand side and the keyboard shortcuts for these commands on the right-hand side. Move through the items with the cursor. You will see a short description of them in the status line.

Copy	copies the marked text into the clipboard (Ctrl + C)
Paste	inserts from the clipboard at the cursor position (Ins, Ctrl + V)
Cut	the same as Copy, except that the marked text is deleted (Ctrl + X)

Activate the 'Copy' command. The marked text is now in the clipboard. You can insert it anywhere within Windows. For a demonstration, now remove the marking in the script by pressing any cursor key. Activate the 'Paste' command or press the Ins key. The text from the clipboard is inserted at the cursor position. Let us assume you don't want to do that, but instead you want to reverse the process. Press the Alt-Backspace combination (Alt+←, Ctrl+Z) or actuate the menu command: 'Edit/Undo' and the former state is restored.

Example exercise

Input restrictions on the demo version

The entries in the course of the example exercise are, of course, subject to the input restrictions of the demo version. This only accepts the following values:

powers of ten of **0, 1, 2** and **5**

Constants: [30, 40, 45, 60, 90, 120, 180, $\sqrt{2}$, $\sqrt{0.5}$]

For example:

10, 0.2, 5kohm, 2mH, 100L, ...

Scripts accompanying the exercise

In the following, you can either follow the exercises exactly, entering the data, or load the script files accompanying this exercise. In the description, it is assumed that you type in the data.

The exercise scripts are numbered consecutively. The first number represents the exercise, the second the script version within an exercise.

Loading the script for the exercise (optional):

- Open the dialog file for loading script files (menu: File/Open).
- In the list of directories, set the directory: '**\AkAbak\Scripts\Examples**' in the center of the dialog (double click on 'Examples' with the mouse).
- In the left-hand list of file names, double click on, for example, the entry '**Demo1.aks**'. The first exercise script for the first exercise is loaded and displayed in the window. The following exercise scripts have corresponding names 'Demo2.aks' etc.

Just snooping around...

To gain an impression of how the simulation works, just load one of the script files from the directory: '**\AkAbak\Scripts\Examples**'. For example:

 Demo script file: **Demo7.aks**

This script describes a small two-way speaker with a simple passive cross over, as is constructed in the following exercise.

Use the simulation of the sound pressure level curve. When the script has been loaded and the script window is active, issue the menu command: '**Sum/Acoustic Pressure...**'. The control dialog for this simulation appears. Leave all the settings as they are and press Enter ↵. In the diagram you now see the sound pressure curve from three listening angles in the vertical.

If you want to close one of the two windows, press the Ctrl+F4 combination.

Designing a two-way loudspeaker

Design data

We will now design a small two-way loudspeaker system with a cross over made of passive components. Two loudspeaker chassis are installed, whose Thiele/Small parameters are determined with free radiation:

Bass loudspeaker

- Resonance frequency $f_s = 50\text{Hz}$
- Equivalent volume to the compliance of the diaphragm suspension $V_{as} = 10\text{L}$
- Mechanical quality $Q_{ms} = 1$
- Electrical quality $Q_{es} = 0.5$
- D.c. resistance of the voice coil $R_e = 5\text{ohm}$
- Inductance of the voice coil $L_e = 1\text{mH}$
- Diaphragm diameter $d_D = 10\text{cm}$
- Diameter of the dust cap $d_{D1} = 1\text{cm}$
- Depth of the diaphragm cone $t_{D1} = 2\text{cm}$
- Frequency for controlling the mass reduction $f_p = 2000\text{Hz}$
- Maximum possible linear diaphragm peak excursion $X_{ms} = 2\text{mm}$
- Nominal electrical loading capacity $P_{elmax} = 80\text{W}$

Tweeter (dome)

- Resonance frequency $f_s = 2\text{kHz}$
- Mass of the vibrating diaphragm assembly, incl. air load $M_{ms} = 0.5\text{g}$
- Mechanical quality $Q_{ms} = 1$
- Electrical quality $Q_{es} = 1$
- D.c. resistance of the voice coil $R_e = 5\text{ohm}$
- Inductance of the voice coil $L_e = 50\text{uH}$
- Diaphragm diameter $d_D = 20\text{mm}$
- Height of the dome $t_{D1} = 5\text{mm}$
- Small horn device (displacement) $t_1 = 2\text{mm}$
- Frequency for controlling the mass reduction $f_p = 10000\text{Hz}$
- Nominal electrical loading capacity
in the frequency range 2.5kHz to 20kHz $P_{elmax} = 80\text{W}$

We will first simulate the system using the simplest possible elements. The element `BassUnit` is used for the bass and the element `Speaker` for the tweeter. These elements, together with their definitions, `Def_BassUnit` and `Def_Speaker`, are also known as 'instant' elements. They are used for quick simulation or as an introduction to the design method.

Step 1: Generating a new script

Issue in the menu: 'File/New...'. Now you are presented with an empty window. In the caption bar is a default file name '`...\Script1.aks`', which you can replace with your own file name when you save the file.

Step 2: Entering the parameters of the bass driver

 Demo script file: **Demo1.aks**

The `BassUnit` element, which you will be installing in the network later, always has a `Def_BassUnit` definition. This carries the loudspeaker parameters and comes at the start of the script. The definition has to be given a name - any name - and as many `BassUnit` elements as required can therefore refer to this definition. The `BassUnit` network element contains information about the position in the network and about the position on the baffle. This structure has proved useful and is used for all driver types that the program supports.

'Def_BassUnit / Calculator' dialog

Now enter the parameters of the definition `Def_BassUnit`. The parameters can be entered directly into the script. Choose the method most convenient for you and open the dialog 'Def_BassUnit / Calculator' (Def/Def_BassUnit... menu).

One of the biggest dialogs in AkAbak opens up. The `Def_BassUnit` dialog is used not only for comfortable data input, but is also a tool for designing bass speakers.

Non-modal dialogs

First a few points about the dialogs. The `Def_BassUnit` dialog is a so-called non-modal dialog. That means you can leave it and re-activate it. If you just want to terminate non-modal dialogs, press the Alt+F4 combination. Esc doesn't work here because it is reserved for stopping any calculation process.

Input

First please enter the aforementioned parameters of the bass driver. The cursor is flashing in the first input box. The input boxes are miniature text editors and work like the script editor. The clipboard can also be used (not via the menu, however, but via the keyboard). Now enter the parameters. Jump from box to box using the Tab key, or using the mouse. Boxes whose names are followed by three stops (e.g. Qms...) have subdialogs in which alternative parameters can be entered. The subdialogs open when the cursor keys Alt+↑↓ are pressed or the right mouse key pressed. When you press ↑↓ the values spin in the IEC row E96 or E12 (Ctrl+↑↓).

How do you enter the data of $V_{as}=10L$? Quite simply: Type '10L' in the V_{as} box. In the box for the diaphragm diameter dD enter '10cm'. AkAbak understands that. You can enter subunits in all numerical input boxes unless the unit is compound (e.g. cm^3 , mm^3 , L for volumes). Take care to distinguish upper and lower case for units (to be able to make a distinction between, for example, Mohm and mohm). For volumes, [L] can be used for liter or [in³] for cubic inch and, for distances, [in] can be used for the inch dimension. Liters and inches cannot be further subdivided. If you only enter the value without a unit, AkAbak uses the appropriate SI unit. Compound units, for example Pas/m^3 or Tm can only be entered in so-called scientific (SCI) notation. A small 'e' is used here to indicate decimal powers, eg. $1.2e-3 = 1.2 \cdot 10^{-3}$.

All the data of the driver have now been entered in the appropriate boxes. However, we still need an appropriate bass enclosure. The design aids of this dialog are not described until one of the following exercises. In the 'Enclosure' group, enter 10L for the enclosure volume in the input box for 'Vb'. Enter a value of 0.1 in the Q_b/f_0 box. Q_b/f_0 is a factor for the acoustic losses in the enclosure. Before you return to the script, another entry has to be made. `Def_BassUnit` is not yet the network element, but the associated definition. Before it can link these two, the definition requires a name. The name may contain any characters (max. 20 characters). Enter it in the 'Identification' box.

Inserting parameters into the script

At the bottom right-hand side in the dialog is the button 'Copy to clipboard and close'. Activate it and AkAbak closes the 'Def_BassUnit / Calculator' dialog and any others involved. When this is done, the entered parameters are correctly formatted and copied into the clipboard. The cursor is flashing in the script again. Press Ins (or menu: Edit/Paste) and the parameters appear in the script. The first word in the first line of the definition is the `Def_BassUnit` keyword. It follows the name in quotation marks

('...') and the parameters in the following lines. All values have units. Unlike in the input boxes, the value must be followed by the unit in the script.

```

Def_BassUnit 'B1'
dD=10cm |Piston
fs=50Hz Vas=10L Qms=1
Qes=0.5 Re=5ohm Le=1mH ExpoLe=0.618
Xms=2mm
Vb=10L Qb/fo=0.1
|Performance in sealed enclosure:
| fc Qtc fD f3
| 70.7Hz 0.442 1.1kHz 130.6Hz
| Lwmax Pelmax UoRms t60 Ripple
| 83.3dB 1.1W 2.33V 0 0

```

The last lines each start with the comment character |. The reproduction characteristics are documented here, as calculated in the 'Def_BassUnit / Calculator' dialog. If you do not require them, you can simply erase them. Mark the lines starting with the | character and press the Del key. The | character introduces a comment. The interpreter ignores everything following it. The comment extends as far as the line end or as far as the next | in the same line.

Step 3: Saving the script

Next save the script to the hard disk. In Windows, commands for saving, printing, etc. are usually in the 'File' menu. Activate the command 'File/Save as'. The file dialog for saving scripts appears. In the list to the right of this dialog, you can see the directory structure of the drive currently active. Select the directory in which you want to save the file. The input box for the file name contains '*.aks'. Replace the text with your own, for example Test1. If an input box is marked, you only need to type into it. The first character erases the old text. Don't forget that the operating system only allows 8 characters for the file name. The file name extension 'aks' is appended automatically. The file is saved when you actuate the 'OK' button.

Step 4: Building up the network for the bass speaker

So far, the script only contains a definition. The currents do not know yet how they are supposed to flow. What you need is a framework in which the structure of the network and the positions of the radiators can be specified. In the AkAbak program, this framework is called *System*. All networks and filter elements following this keyword in the text form part of a network. The next network starts with the keyword *System* again. Start a new line in the script, type the word *System* followed by a name and then move the cursor to the next line. Giving names to the System's and components helps the simulator to distinguish them when you use the simulation listed in the 'Inspect'-menu. Only System's and components with an unique identifier are listed here.

Input in the 'BassUnit' dialog

The parameters of the *BassUnit* network element can be either entered manually or a dialog used. Use the dialog (Net/ Transducer/ BassUnit menu). This dialog is much smaller than the dialog of *Def_BassUnit*. The cursor is flashing in the input box for the element name. It is optional here. Leave the box empty and jump directly to the first box of the network node *s*. Enter a 1. The input voltage of the network is always at node 1 and ground node at zero. The 0 in the box of for node *t* remains.

The right-hand list contains the names of all *Def_BassUnit* definitions. In this case only the one that you entered when naming *Def_BassUnit*. Click on the entry with the mouse or use the cursor keys $\uparrow\downarrow$, to copy the entry into the box above it. Please do not use the 'Position of radiation center...' button yet. A sub-dialog opens to establish the position of the bass speaker on the baffle. The position is changed later. At first, the driver is located at the origin of the baffle co-ordinate system. Since all entries have been made, close the dialog again using the 'Copy and close' button. The data are now in the clipboard and are inserted at the cursor position in the script when you press **Ins**. The script now looks like this:

```

Def_BassUnit 'B1'
  dD=10cm |Piston
  fs=50Hz Vas=10L Qms=1
  Qes=0.5 Re=5ohm Le=1mH ExpoLe=0.618
  Xms=2mm
  Vb=10L Qb/fo=0.1

System 'Bass'
  BassUnit 'B11' Def='B1' Node=1=0
  x=0 y=0 z=0 HAngle=0 VAngle=0

```

Step 5: Simulating the sound pressure level

You have now made all the preparations to allow you to simulate a complete bass system. First look at the on-axis sound pressure curve of this bass unit at an input voltage of 1 volt.

Simulation - sound pressure level

Start the simulation using the 'Sum/ Acoustic pressure' command (keyboard shortcut: F5). The 'Acoustic pressure' control dialog appears. The dialog has some control elements. First leave everything just as it is and press the 'OK' button or simply Enter ↵. The dialog disappears and a diagram window opens (Fig. 1). A curve is drawn in the diagram, which corresponds to the sound pressure level at an input voltage of 0.707 volt rms at a distance of 1m.

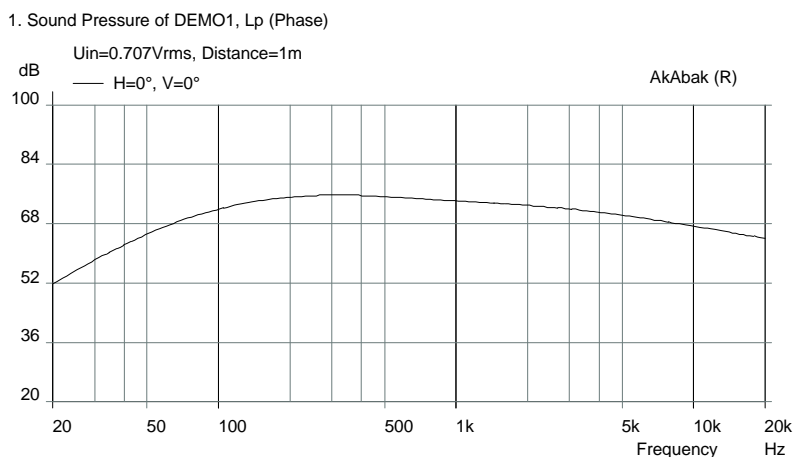

Fig. 1 Curve of the on-axis sound pressure level of the bass speaker

Diagram

Before you do the next step, investigate the things you can do with the diagram. Double click on the left ordinate area within the numbers. The ordinates are adapted so that you can see the whole curve. Double click on the area again and the old state is restored. You can also zoom out a portion of the curve. First a zoom window has to be pulled out. If you press the left mouse key, hold it down and then move the mouse, a rectangle is drawn. The content of this rectangle is zoomed when you release the mouse key. A double click on the ordinate restores the old state. The network is not recalculated during zooming. The zoom depth is therefore limited. There is a trick for increasing the resolution in the zoom window, which you will learn about later on. The same works with the abscissa but in this case drag the mouse from the left to the right and double-click on the abscissa numbers to restore the previous setting.

Phasing in the marker

Click on the graphs with the mouse or press one of the cursor keys. A small cross and a window containing values appears. The upper value is the abscissa value and the lower one the ordinate value of the marker position. The border of the box has the colors of the graph on which the marker is located. The cursor keys ←, →, End and Home move the marker on the graph. Its speed increases if you press Ctrl at the same time. The + and - keys locate the maximum and minimum of the graph. Since a diagram can represent up to four graphs simultaneously, the ↑↓ are reserved for changing

from one graph to the other. If you move the marker while holding down shift ↑, a second cross appears and the panel displays the difference between the two marked points. The marker disappears when you press Esc. By the way: If your monitor does not display the marker very well, you can change its color (File/ Preferences/ Screen diagram style... menu).

'Diagram Range' dialog

Double click on the area within the diagram region or simply press Enter↵ or else use the Edit/ Diagram range... menu. The 'Diagram Range' dialog opens. Here, you can enter the ordinates and the abscissa manually. If you want, print out the diagram (File/ Print menu).

Step 6: Simulation of the acoustic power

Leave the diagram of the sound level on the screen and activate the script window again (simply click anywhere on the area of this window or press the Ctrl+F6). Now activate the 'Sum/Acoustical Power...' menu command. The 'Acoustical Power' control dialog opens. In the bottom right of the dialog is the 'Integral method' group. The switch is set to 'Cross' and the 'Steps of integration' boxes contain 15° and 9°. The acoustic power is calculated by integration of the sound intensities on an envelope surface around the speaker. The 'Cross/ Area' switch is used to control the integration. If it is set to 'Cross', all sound intensities of a horizontal and a vertical meridian on the integration sphere are added together. If the switch is set to 'Area', AkAbak adds up the intensities on the entire sphere. With 'Steps of integration' you control the density of integration. These switches have been introduced to allow computation times to be reduced, since this simulation is very computer intensive. Since, at present, only one radiator exists, which is symmetrical with respect to the origin of the baffle co-ordinate system, leave the setting as it is.

Since, at the moment, we simulate a loudspeaker placed in an infinite baffle (default setting) the integration should be only done for a halve space. Thus switch on the '2pi-sr' box.

Press 'OK', therefore, to start the simulation. You will see that the curve grows more slowly than the sound pressure level curve. By the way, as you can see from the status line, the computation can be terminated at any time with Esc.

Step 7: Comparison of curves

It is conspicuous that the curve of sound power falls off earlier at higher frequencies than the sound pressure curve (Fig. 2). The second curve is the quality factor Q of radiation and rises at high frequencies due to beaming. For a better comparison, place one window above the other. To do this, activate the 'Window/Tile Diagrams' menu command.

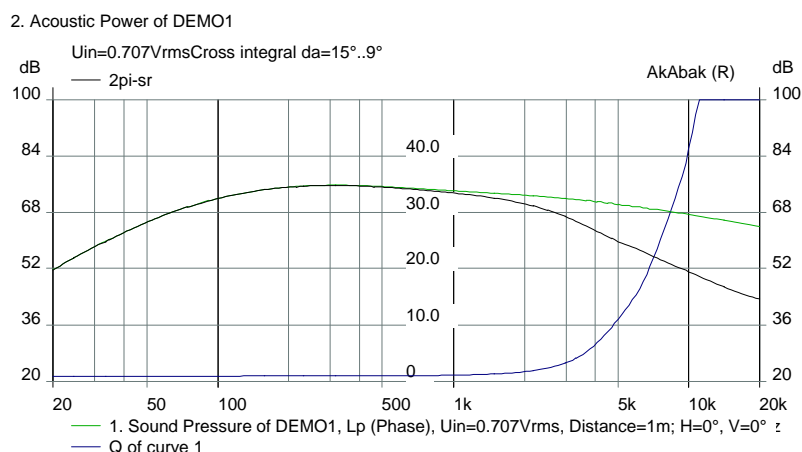

Fig. 2 Acoustic power level of the bass speaker and sound pressure level curve as in Fig. 1 below: Quality factor Q

Copying graphs

You can also go a step further and copy the graphs from one diagram into the diagram of the other window (Fig. 2). To do this, click on the legend of the graph for acoustic power and keep the mouse key pressed. The legend is shown in inverse display and the mouse cursor changes. Now move the

cursor into the diagram area of sound level and then let go. Two ordinates are now shown. The right-hand ordinate forms part of the so-called 'guest graph', in this case the acoustic power. The legend of the guest graph is always below the diagram.

The curve for power has to decrease earlier since, from a certain frequency, (directivity frequency), the radiated sound pressure decreases towards the side. It is only directly in front of the loudspeaker, i.e. on-axis, that the sound pressure remains constant, at least in the present case of a flat diaphragm. The pitch of the curve is at the expense of voice coil induction.

Step 8: Sound pressure level at different listening angles

To be able to investigate the radiation behavior in greater detail, the example in the exercise simulates the sound pressure curve from three different listening angles. To re-simulate the sound pressure activate the diagram with the sound pressure simulation and issue the menu 'Calc/ Simulate again...' or Alt+Y. In the 'Listening angles' group of the control dialog switch on the 'Horiz' box and the three Graph boxes 1, 2 and 3. Then press 'Ok'.

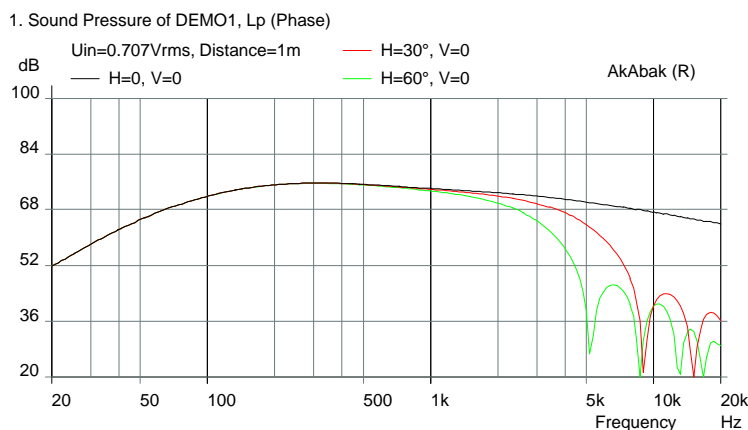

Fig. 3 Sound pressure level curve at the listening angles of 0°, 30° and 60°

You now see that three graphs are drawn in the diagram (Fig. 3). The first is the sound pressure curve directly in front of the loudspeaker again. For the next, the listening point is displaced to the left by 30°. (seen from the speaker). The third indicates the curve at 60°. Please copy the graphs of the acoustic power into this diagram again. You can now easily see why the power is reduced.

Step 9: Recomputing changes in the script directly

 Demo script file: **Demo2.aks**

AkAbak has a very useful function that allows graphs to be recomputed. All settings of the diagram are preserved. You can therefore see the effects of changes in the script immediately. Leave everything just as it is and activate the script. Now additionally enter the following in the Def_BassUnit line containing the diaphragm diameter dD=10cm (you can delete the commentary 'lpiston'):

dD1=1cm tD1=1cm fp=2000Hz

The definition then appears as follows:

```
Def_BassUnit 'B1'
  fs=50Hz Vas=10L
  Qms=1 Qes=0.5 Re=5ohm Le=1mH
  dD=10cm dD1=2cm tD1=1cm fp=2000Hz
  Xms=2mm mb=1
  Vb=10L Qb/fo=0.1
  ...
```

These entries describe the diaphragm shape in detail. So far, we have been assuming it was a vibrating piston since only the diaphragm diameter d_D had been entered. Most bass speakers have a conical shape. In this case d_{D1} is the diameter of the dust cap or the inner diaphragm and t_{D1} is the depth of the cone from the edge of the suspension as far as the dust cap. This does not affect the position of the driver on the baffle. The frequency f_p is used to control the effect of the so-called mass-reduction or area-reduction of the diaphragm. At high frequencies, it is no longer the entire cone that vibrates, but only a part of the diaphragm, which gets smaller with increasing frequency. With the exception of the eigen-vibrations that normally occur, AkAbak takes into account the altered effective mass and the reduced diaphragm shape. In the case of a conical diaphragm, the external diameter is reduced. In the case of the dome, a portion in the center of the diaphragm is hollowed out, so that an ring radiator is produced. The diaphragm area-reduction has an effect on the radiation characteristics and on the radiation impedance.

If you have entered the two parameters, activate the 'Calc/ Simulate again' menu command or press Ctrl+Y. In the status line, you see the message 'long computation', and the mouse cursor is an hourglass. What is happening? AkAbak is now recomputing the simulation for each diagram window having the same name as the script window. Since this example includes a diagram window for the acoustic power, the computation takes a particularly long time. Wait until the message disappears.

You can also recalculate a single diagram. For this purpose the diagram window has to be enabled before you can issue the command for recomputation. That means that, when the script window is activated, all the associated diagrams are recomputed. If only one diagram window is active, only this diagram is recalculated. Reduced diagrams and guest graphs are not included in the recomputation.

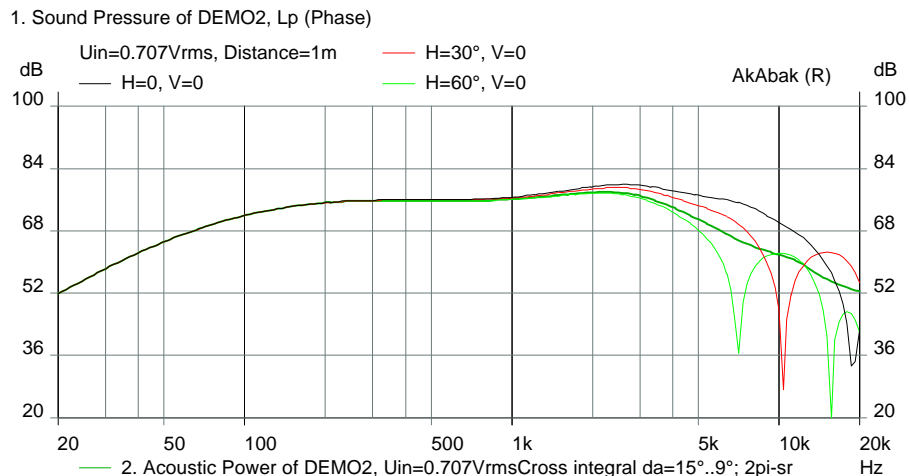

Fig. 4 Sound pressure curves at listening angles of 0°, 30° and 60° and the acoustic power level of the bass loudspeaker with conical diaphragm

What can you see in Fig. 4? The acoustic pressure and the power now fall off more steeply at higher frequencies. The same applies to the on-axis sound level. This falling off is caused by interferences resulting from the diaphragm shape. The acoustic center of the radiator migrates inwards. Because f_p has been entered, the diaphragm diameter becomes frequency dependent - the area, and therefore the mass, is reduced. At extremely high frequencies, virtually only the inner diaphragm radiates sound. The radiation characteristic broadens (Fig. 5) and a slight amplification occurs in the upper frequency range. The hollow of the cone changes the radiation impedance curve, and thus causes an excessive increase in the sound-level curve in the frequency range around 2000Hz.

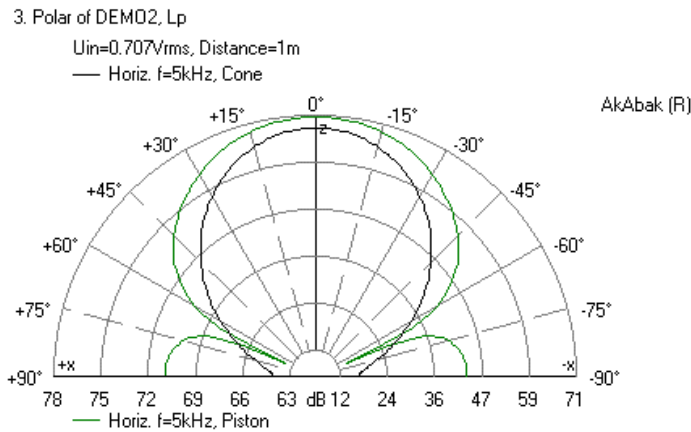



Fig. 5 Directivity of cone (3 lobes) and piston (1 lobe) at f=5kHz

In practice, the eigen-vibrations of the diaphragm in this frequency range are also to be added. However, AkAbak cannot simulate these at the moment. It is interesting to experiment here. Comment out some of the diaphragm parameters by entering the '|' character before the parameter. The '|' character is effective until the end of the line or as far as the next comment character. Then repeat the simulation with Ctrl+Y or Alt+Y.

Step 10: Entering the Def_Speaker definition

 Demo script file: **Demo3.aks**

How do we proceed now? Of course you can investigate the bass unit further. (see, for example, the simulations in the Inspect/ menu). The next step in designing the two-way speaker is to add the tweeter, since the sound level curve shows that the speaker at present only radiates uniformly up to maximum 3 kHz.

First enter the parameters of the tweeter, as described above, as a definition Def_Speaker. Like the BassUnit element, the speaker element is an 'instant' element. It has been found to be a very compact and practical means of installing a complete loudspeaker. Your tweeter is in this category since it is rigidly installed in a housing.

It should be noted that the speaker element implements a very simple model. For example, some dome mid-range units are not correctly simulated by the Speaker element, since the sound from the diaphragm reverse is directed via an acoustic vent into the enclosure behind the magnet. A Helmholtz resonator is produced here, whose resonance is reflected in the sound level curve. If you want to simulate such a mid-range unit more accurately, use the elements Driver, Duct and Enclosure.

Def_Speaker dialog

The Def_Speaker definition is again entered with the aid of a dialog, 'Def/ Def_Speaker' menu. Fill in the boxes with the data as given for the dome tweeter described above. Don't forget the obligatory name here. When you reach the box 'diaphragm dimensions', press the cursor keys Alt+↑↓ or click on the input box with the right-hand mouse key.

'Diaphragm' sub-dialog

The 'Diaphragm' sub-dialog appears. You can use this dialog to make all entries relating to the radiation diaphragm. First select the diaphragm shape ('Circular' and 'Convex Dome'). Enter the diaphragm diameter dD, the recessing of the dome in the baffle t1 and the mass-reduction frequency fp. For a domed diaphragm, only the dome height tD1 is required. The area of the inner diaphragm is zero. Enter the dome height tD1 in the box at the lower right-hand side. The dialog is closed and your entries in the Def_Speaker dialog are saved. When you have entered everything, close the dialog again using the 'Copy and close' button. Then place the cursor in an empty line in the script above the

System keyword and after the Def_BassUnit definition. Press **Ins** and the parameters of Def_Speaker are inserted.

Step 11: Building up the network for the tweeter

Since the example in the exercise constructs a cross over with purely passive components, you basically only needed one system, i.e. only one network. Since, however, low-pass and high-pass of this cross over are not networked together, the example utilizes the advantages of two systems. Each of these networks has at first only one element, namely the loudspeaker. First of all, therefore, please design the cross over abstractly using the filter elements. AkAbak can then synthesize the passive filter network.

After the parameters of BassUnit, enter the System keyword again and enter a name. Then open the 'Network Element Speaker' dialog via the 'Net/ Transducer/ Speaker...' menu. As with the BassUnit dialog, enter the data in the dialog and close it using 'Copy and close'. Enter the parameters from the clipboard into the script below the System keyword.

Before you start the simulation, you have to change something else in the BassUnit element. At present, both loudspeakers radiate from the same position. The bass therefore has to be moved downwards by 10cm. Change the BassUnit element by moving its vertical position to $y=-10\text{cm}$.

The script now looks like this:

```
Def_BassUnit 'B1'
  fs=50Hz Vas=10L
  Qms=1 Qes=0.5 Re=5ohm Le=1mH
  dD=10cm dD1=2cm tD1=1cm fp=2000Hz
  Xms=2mm mb=1
  Vb=10L Qb/fo=0.1

Def_Speaker 'S1'
  dD=2cm tD1=5mm t1=2mm fp=10kHz |Convex Dome
  fs=2kHz
  Qms=0.5..Qes=1 Re=5ohm Le=20uH

System 'Bass'
  BassUnit 'B11' Def='B1' Node=1=0
  x=0 y=-10cm z=0

System 'High'
  Speaker 'S11' Def='S1' Node=1=0
  x=0 y=0 z=0
```

Step 12: Simulation of woofers and tweeters

Simulate the sound pressure level again from different listening angles and the acoustic power as above. Consider the sound pressure curve from vertical listening angles, as well. As you see, the frequency range 1kHz..6kHz has a ripple of the sound pressure and power levels.

Using Labels

To investigate the sound pressure of the woofer, tweeter and the sum total use the Label feature. Since named System's are valid labels open the control dialog of 'Sum/Acoustic pressure' and click on 'Multi-Labels'. Then check three graphs and select in the first list '<all>', in the second list 'Bass' and in the third select 'High'. When you finished click 'ok' to display the three graphs.

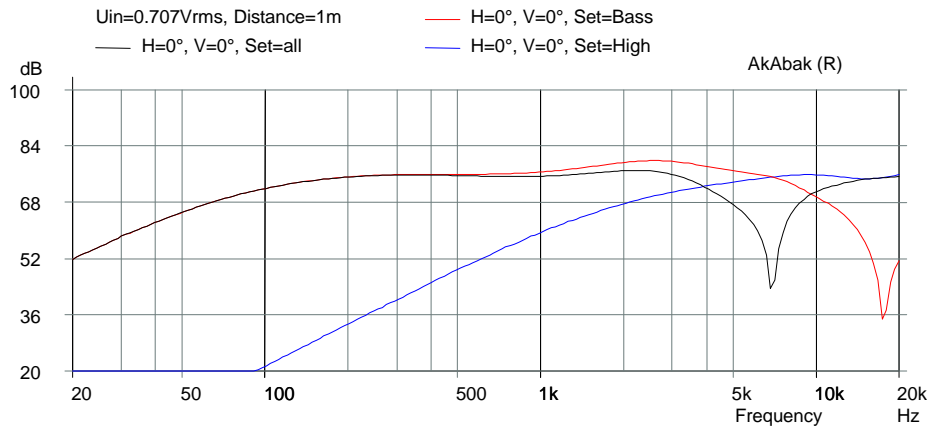

Fig. 6 Sound pressure level of Bass, High and total sum using Labels

Step 13: Simulation of the diaphragm excursion of the tweeter

Start the simulation of the diaphragm excursion (Inspect/ Excursion). The lower part of the control dialog that opens is known from the already familiar control dialogs of the sound level and the acoustic power. The upper part is used for selecting the element that is to be examined. The lists contain only those elements for which the simulation of the diaphragm excursion is relevant (and also only those which have a unique identifier). A maximum of three curves of the diaphragm excursion can be displayed. In this case only select the speaker element.

2. Excursion of DEMO3, Amplitude

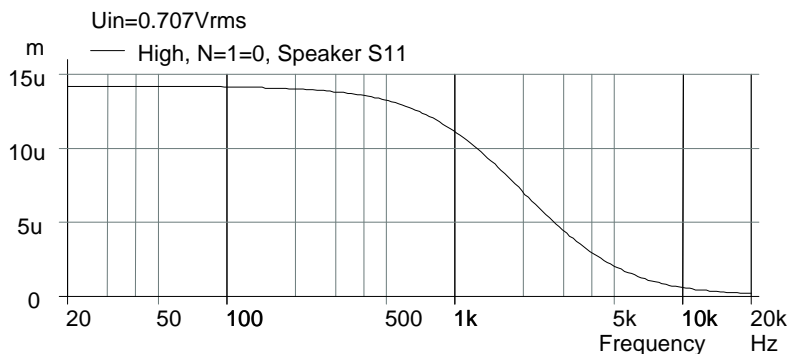

Fig. 7 Diaphragm excursion curve of the tweeter

Click on the 'OK' button and the diagram is drawn (Fig. 7). However, you do not see a graph. This is because the excursion of the tweeter is extremely small. Double click on the left ordinate area. The diaphragm excursion of the tweeter is displayed as a function of frequency (peak value). As you can see, the curve is that of a low-pass function. At low frequencies, its curve is constant and starts to fall off at approx. 300Hz. At approx. 1.5kHz, the excursion is only half. If you know the maximum excursion of the loudspeaker, it is easy to calculate the loading capacity with the aid of this diagram.

Step 14: Designing the cross over

 Demo script file: **Demo4.aks**

A cross over that keeps low frequencies away from the woofer and high frequencies away from the tweeter will improve the reproduction and performance.

'Filter' dialog

With the limitations of the demo version, set the cross over frequency to 5kHz and look for an appropriate filter circuit. To do this, open the filter dialog in the 'Filter/Filter Dialog...' menu. This dialog contains some tools for generating and investigating certain kinds of filters and characteristic curves. Enter in 'Filter pole frequency fo' the cross over frequency '5kHz'.

Sub-dialog 'Standard lowpass functions'

In the next step, you can have AkAbak calculate a transfer function. Click on the 'Standard lowpass functions...' button. A sub-dialog opens. In the first input box, you can enter the order of the filter. Leave the '2' where it is, since we want to generate a 2nd order transfer function. The list contains a selection of typical characteristic curves, some of which are of particular interest for constructing cross overs. Choose the Butterworth characteristic curve. Now click on the 'OK' button. The dialog closes and the 2nd order Butterworth transfer function is now entered in the filter dialog in the 'Transfer 2' group.

At the top is the numerator polynomial, and below it is the denominator polynomial. Before this transfer function can be exported as a script element, it has to be in the 'Transfer 1' input box. Therefore click on the 'Copy to 1' button. The multi-line input box then contains:

```
b0=1;  
a2=1; a1=1.414214; a0=1;
```

b0 is the numerator coefficient, a2, a1 and a0 are the denominator coefficients. The index is the same as the power of the frequency variable. The entries here have to be separated by a semicolon. There is a reason for this: The entries of the filter coefficients of the `Filter` element may also be formulae. For example, instead of $a1=1.414214$ you can also enter: $a1=\text{sqrt}(2)$, where 'sqrt' is the square root. In the next step, generate the symmetrical high pass for this function. Click on the 'Lowpass to highpass' button in the 'Transfer 2' group. The transfer function in the 'Transfer 2' group is reflected. For Butterworth functions, not very much happens. Only the numerator is changed. Apart from decimal powers of 0,1,2 and 5, the demo version also accepts certain constants, such as roots of 2 and 0.5.

Diagram in 'Filter' dialog

The dialog now contains two transfer functions. The low pass is in the group 'Transfer 1' and the high pass in the group 'Transfer 2'. Click on the 'diagram' button and the modulus of the transfer function is drawn. You can see how the low pass and high pass intersect at 5kHz. Their level in this case is -3dB. The third curve results from the sum of the other two. Although that does not look good. The example in the exercise is intended to show that, at the cross over frequency, complete extinction takes place, i.e. the phases of the two signals are displaced by 180° at this point. To correct this problem proceed in the filter dialog. (Simply click on its area. You do not need to close the diagram window). Jump into the 'Transfer 1' input box and place a minus sign before the one of b0 ($b0=-1$). Click on the 'diagram' button again. Now the diagram looks better. Instead of an extinction, there is a slight emphasis at the cross over frequency.

Copying the coefficients into the script

Please close the diagram window now, or activate the filter dialog. Copy the transfer function of the 'Transfer 1' group into the script. To do this, click on the 'Copy function 1 to clipboard and close'. Then place the cursor in an empty line in the script below the `BassUnit` parameters, i.e. before the second System and press **Ins** to insert the filter parameters. What does AkAbak do with this Filter element? The filter element has no node entries. Thus the filter is not part of the network of the System. The program multiplies together all filter elements listed within a system. The result is used to weight the input voltage of the network U1. You can generate the high-pass filter for the tweeter yourself:

Filter dialog → Filter pole frequency fo (5kHz) → Standard lowpass functions... → 2nd order Butterworth → Lowpass to highpass → Copy to 1 → Copy and close.

Enter this filter into a free line below the `Speaker` parameters, i.e. at the script end. You can also generate the high-pass filter more quickly, by the way, by marking the low-pass filter, copying it into

the clipboard (Edit/Copy menu) and then inserting it again. The high-pass transformation in the case of a Butterworth-function is very simple. Replace the numerator coefficients $b_0=-1$ with $b_2=1$.

The script now has the following text:

```
Def_BassUnit 'B1'
  fs=50Hz Vas=10L
  Qms=1 Qes=0.5 Re=5ohm Le=1mH
  dD=10cm dD1=2cm tD1=1cm fp=2kHz
  Xms=2mm mb=1
  Vb=10L Qb/fo=0.1

Def_Speaker 'S1'
  fs=2kHz Mms=0.5g
  Qms=0.5 Qes=1 Re=5ohm Le=20uH
  dD=2cm tD1=5mm t1=2mm fp=10kHz |Convex Dome
  mb=1

System 'Bass'
  BassUnit 'B11' Def='B1' Node=1=0
  x=0 y=-10cm z=0
  Filter 'F1'
  fo=5kHz
  {b0=-1;
  a2=1; a1=1.414214; a0=1; }

System 'High'
  Speaker 'S11' Def='S1' Node=1=0
  x=0 y=0 z=0
  Filter 'F1'
  fo=5kHz
  {b2=1;
  a2=1; a1=1.414214; a0=1; }
```

Step 15: Simulation with filters

The script now describes a complete speaker with cross over, which could even have been built up with active filters. Now simulate the sound pressure level from different angles and the acoustic power of this circuit. As you can see, the result is not very satisfactory. There is a dip in the on-axis response. We try an invert one of the filters by removing the minus-sign at the Bass-channel ($b_0=1$). Now the on-axis sound pressure looks much more linear. At vertical listening angle there is rippling in the sound level curve. This ripple, however, is unavoidable with this type of design. It is caused by interferences resulting from the difference in travel time caused by the displacement of woofer and tweeter. Use the Label-feature to display the Bass, High and sum curves simultaneously or select 'Multi-angles' to simulate several listening angles.

Taking into account the radiation environment

 Demo script-File: **Demo5.aks**

To be able to continue the design process properly, it is necessary to consider the radiation environment of the speaker. Until now it was assumed that the woofer and tweeter were embedded in an infinite baffle. To achieve this, you would have to embed the speaker in a wall. In practice, the radiation conditions are mainly mixed. At high frequencies the loudspeaker presents the radiators with an infinite baffle; at low frequencies, on the other hand, the sound is diffracted around the speaker and free radiation conditions prevail. In the low frequency range, the level of the sound pressure is about 6dB and that of the power is 3dB lower than at high frequencies. AkAbak can take into account this diffraction effect. To do this, it needs an entry for the width and height of the baffle. Enter $WEdge=15cm$ $HEdge=30cm$ after the position details of woofer and tweeter. Carry out the simulation again. Now you see the reproduction of the loudspeaker when it is mounted freely somewhere in the room, remote from reflecting walls. The sound level and the acoustic power have dropped off in the bass region (Fig. 8).

The diffraction model implemented in AkAbak uses the technique of far-field image radiators. It influences both the radiation and the radiation impedance. The method provides a good compromise between correctness and practicality for calculating the sound diffraction, which is generally very difficult to simulate.

```

...
System 'Bass'
  BassUnit 'B11' Def='B1' Node=1=0
    x=0 y=-10cm z=0 WEdge=15cm HEdge=30cm
  Filter 'F1'
    fo=5kHz
    {b0=-1;
      a2=1; a1=1.414214; a0=1; }

System 'High'
  Speaker 'S11' Def='S1' Node=1=0
    x=0 y=0 z=0 WEdge=15cm HEdge=30cm
  Filter
    fo=5kHz
    {b2=1;
      a2=1; a1=1.414214; a0=1; }

```

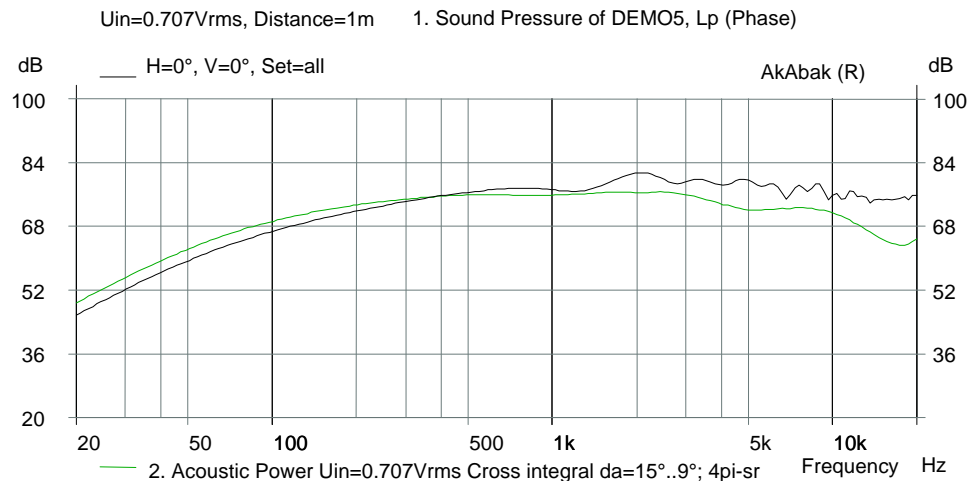

Fig. 8 On-axis sound pressure curve and acoustic power curve for woofers and tweeters with filters mounted on finite baffle

Diaphragm excursion

The result of the diaphragm excursion simulation for the tweeter is also interesting (Fig. 9). The diaphragm excursion is maximum at approx. 3.7kHz and the excursion is damped by approximately an eighth of the maximum of the unfiltered tweeter (guest graph or Fig. 7).

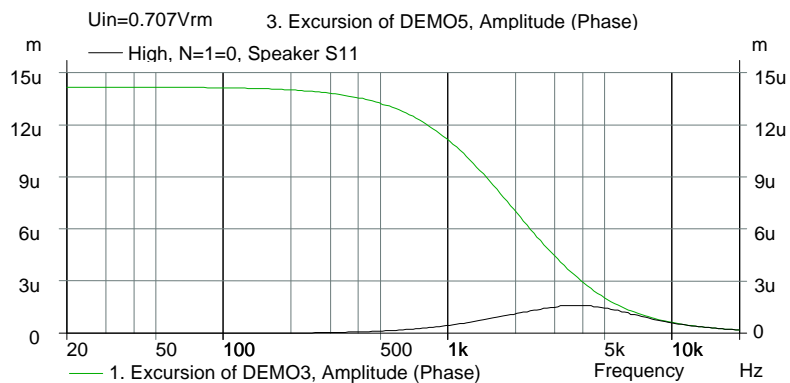

Fig. 9 Diaphragm excursion curve of the filtered and unfiltered tweeter (guest graph)

Step 16: Synthesis of the passive network

It is useful to create a new script for the passive version of the design. First save the currently active script without closing it. Leave the simulations of the sound level and the power on the screen. You will need them later as a comparison. Create a new script (File/New menu). Then activate the old script window and mark the entire text. To do this, jump to the text start (Ctrl+Home), keep Shift depressed and additionally press the Ctrl+End combination. After these maneuvers, the entire text is shown inverse. Copy the text into the clipboard (Edit/ Copy menu or Ctrl+C). Activate the new window and paste the text (Ins key). You now have two scripts with the same text. Save the new script under a suitable name (File/Save or File/Save as menu). To reduce cluttering of the screen, reduce the old script and the diagrams to an icon.

Driving-point impedance

For the synthesis of the passive network from the abstract filter element, you require the value of the terminating resistor of the network. The voltage transfer function of the synthesized network corresponds exactly to the transfer function of the filter, if the latter resistor is real and frequency-independent. This is by no means true for the driving point impedance of dynamic drivers, however. There are two ways of circumventing this problem. The first way is to connect a dual network in parallel to the driver and the following elements, so that the driving point impedance is constant and real, or at least a good approximation. This method is often very complicated. For very steep filter characteristics and critical settings, such a network is essential. The second way can be used if the steepness of the filter curves is moderate and there is a low impedance gradient. In this case the value of the input impedance of the respective driver is estimated from the diagram of the input impedance.

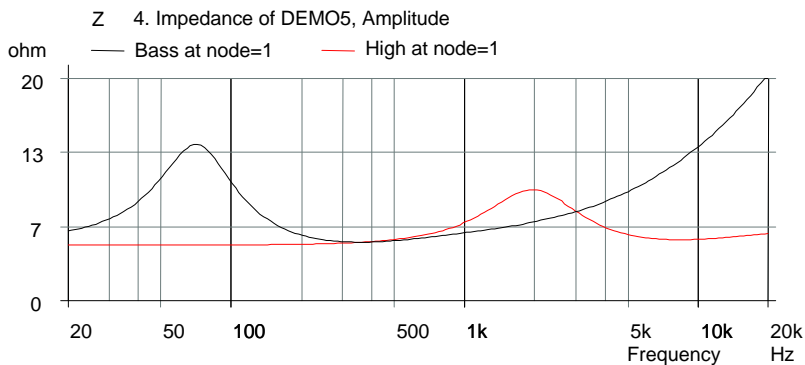



Fig. 10 Driving point impedance of woofer and tweeter

First display the curve of the driving point impedance of woofer and tweeter. Activate the 'Inspect/Network impedance...' menu command. In the control dialog, assign 'Bass' system to Graph 1 and 'High' system to Graph 2 and start the simulation. Double click on the diagram area again to bring the graphs into the display (Fig. 10). The frequency of the cross over in the example of the exercise is 5kHz. The impedance curve of the woofer and tweeter in this frequency range is anything but constant. The woofer has a high voice-coil inductance and the resonance of the tweeter is very close to the cross over frequency. Before you can design the passive cross over, you must first try to smooth the impedance curves in the frequency range around 5kHz.

Impedance compensation network

AKAbak has a tool for smoothing the impedance curve of electrodynamic drivers: 'Tools/ Impedance Compensation' menu. Under the restrictions of the demo version, however, it is very difficult both to describe it and use it. Enter the given compensation networks by hand, therefore, or load them.

 Demo script file: **Demo6.aks**

```
...
System 'Bass'
  | Impedance compensation
  | Capacitor Node=1=0 C=20uF Rs=5ohm
```

```

BassUnit 'B11' Def='B1' Node=1=0
  x=0 y=-10cm z=0 WEdge=15cm HEdge=30cm
Filter 'F1'
  fo=5kHz
  {b0=1;
  a2=1; a1=1.414214; a0=1; }

System 'High'
  | Impedance compensation
  Capacitor Node=1=0 C=20uF Rs=10ohm Ls=0.5mH
  Speaker 'S11' Def='S1' Node=1=0
  x=0 y=0 z=0 WEdge=15cm HEdge=30cm
  Filter
  fo=5kHz
  {b2=1;
  a2=1; a1=1.414214; a0=1; }

```

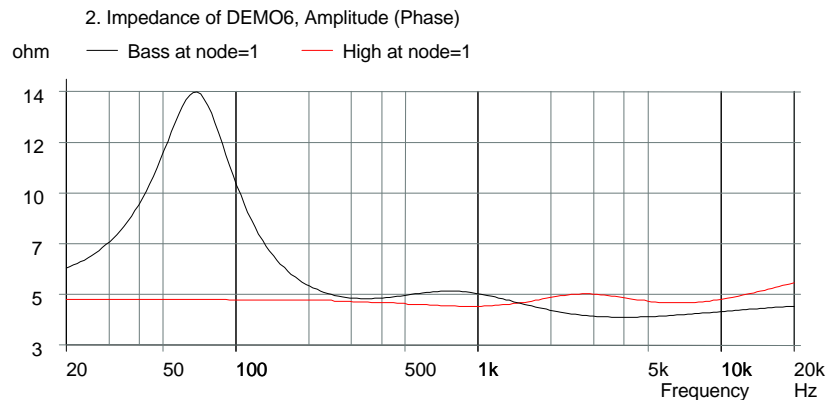

Fig. 11 Driving point impedance of woofer and tweeter, compensated in the upper frequency range (in the range of possible accuracy of the demo version)

Fig. 11 shows the compensated impedance curves of woofer and tweeter. The components connected in parallel with the drivers only smooth the curves in the range of the cross over frequency 5kHz. The rounding of the component value to the values allowed in the demo version results in a rippling curve. At 5kHz, the impedance values of both curve are close to 5 ohm.

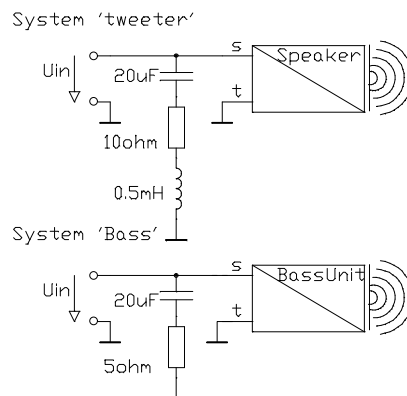



Fig. 12 Circuit diagram of the woofer and tweeter with impedance compensation

Fig. 12 shows the circuit diagram with the drivers and their compensation network. In the script, the components R_{Lt} , R_{ce} , C_e and R_{Lh} , L_m , R_m and C_m are combined in one `Capacitor` element. The resistances and the inductance are assigned to the loss parameters of the capacitor. The individual elements could also be entered discretely by means of the elements `Resistor` and `Coil`.

Synthesis of the low pass

 Demo script file: **Demo7.aks**

In the script, place the cursor somewhere within the filter element of the bass system. Start the synthesis using the 'Filter/LCR synthesis...' menu command. The control dialog of the passive synthesis appears. At the top you can see the transfer function again. The cursor is flashing in the 'RL Loading resistor' input box. Here, enter the rounded down value of 5 ohm you have just determined. Since the box is already correctly filled in for the filter frequency, you only need to press Enter (Network type 1 button). The right-hand list is filled in with the network; a coil, a capacitor and a resistor. The resistor is the loading resistance as entered.

In practice there are no ideal coils. All coils have at least the wire resistor in series with the inductance. In the case of coils having a core, the core losses are added. For cross overs for loudspeakers this series resistance has an undesirable effect in that the impedance level of the entire network is very low. Each ohm costs power and falsifies the filter characteristics. Although capacitors also do not represent pure capacitance's, their losses can usually be neglected in conventional cross over circuits. AkAbak's synthesis method can generate networks with dissipative inductances and non-dissipative capacitances. To do this enter in the input box 'QL Quality of coils', some values for the quality of the coils at 5kHz: For example Q=5, 10, etc. Start the synthesis again. As you see, the values have changed and the entry for the coil is followed by the value of the loss resistance that generates the entered quality. With the introduction of dissipative coils, the network damps the transmission.

In this demo version exercise we take the coils as non-dissipative. Delete the value in the 'QL Quality of coils' input box and evaluate the non-dissipative network. Press the 'Copy and close' button and enter the elements before the `BassUnit` element and after the `System` keyword. As you can see not only a coil and capacitor element is inserted but also a paragraph called `SynthesisInfo`. Here the transfer function is repeated and the parameter for the synthesis procedure are listed. When you move the cursor in the lines of `SynthesisInfo` and issue 'Search/Current element' or press Ctrl+E then the synthesis dialog opens again.

The original Filter element should be deleted since otherwise the loudspeaker would be filtered twice. Change the node numbers of the `Capacitor` element and of the `Bassunit` element to `Node=2=0`. For the purposes of the exercise, the values of the passive filter are rounded down to `L=0.2mH` and `C=5uF`. The parameters of this system now have the following appearance:

```
...
System 'Bass'
  Coil      Node=1=2  L=0.2mH
  Capacitor Node=2=0  C=5uF
  SynthesisInfo
    Passive FirstNode=1  RL=5ohm  QL=0
    fo=5kHz  vo=1
    {b0=1; a2=1; a1=1.414214; a0=1; }
  |Impedance compensation
  Capacitor Node=2=0  C=20uF  Rs=5ohm
  BassUnit 'B11' Def='B1' Node=2=0
    x=0  y=-10cm  z=0  HAngle=0  VAngle=0
    WEdge=20cm  HEdge=50cm...

System 'High'
...
```

The node numbers have the function of unequivocally fixing the structure of the network. The driving point voltage is at nodes 1 and 0 (ground). The coil leads to the next node (2). From there, one capacitor leads to ground (0). Simulate the curve of the sound pressure level and the acoustic power again. Compare the curves with the simulations in the previous script.

Synthesis of the tweeter part

Activate again the diagram window showing the input impedance curve, and note the curve for the tweeter impedance. Select `RL=5ohm` as load resistance. Place the cursor of the script in the `Filter` element of the tweeter so that the synthesis dialog can read in the data. Open this dialog (Filter/LCR

synthesis menu). Enter '5ohm' for the loading resistor. Start the synthesis and close the dialog. Subsequently insert the elements into the script before the `Capacitor` and after the word `System`.

Adapt the node numbers of the `Capacitor` and the `Speaker` and delete the `Filter` element. In the exercise, the values of the passive filter are rounded down to $L=0.2\text{mH}$ and $C=5\mu\text{F}$. The script of the tweeter channel now looks like this (📄 Demo file: **Demo7.aks**)

```

...
System 'High'
Capacitor Node=1=2 C=5uF
Coil      Node=2=0 L=0.2mH
SynthesisInfo
  Passive FirstNode=1 RL=5ohm QL=0
  fo=5kHz vo=1
  {b2=1; a2=1; a1=1.414214; a0=1; }
|Impedance compensation
Capacitor Node=2=0 C=20uF Rs=10ohm Ls=0.5mH
Speaker 'S11' Def='S1' Node=2=0
  x=0 y=0 z=0 HAngle=0 VAngle=0
  WEdge=20cm HEdge=50cm

```

Please simulate this circuit. The limits of the demo version compel to round off errors. Thus the synthesized curves correspond not exactly to the design with abstract Filter elements.

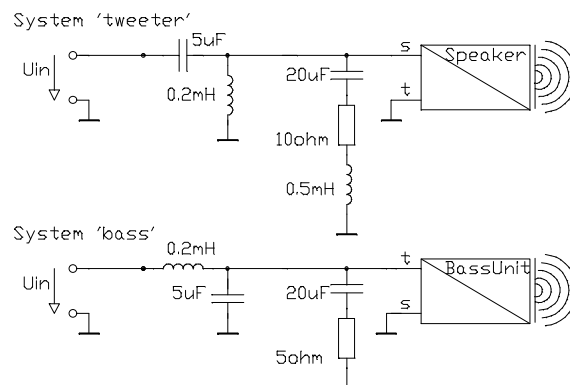

Fig. 13 Circuit diagram of the passive cross over and the impedance compensation

Step 17: Reflectors

📄 Demo script file: **Demo8.aks**

The radiation conditions analyzed so far are idealized. In practice, the speaker will be located close to walls that reflect the sound. Reflective walls near to the loudspeaker are, so to speak, part of the sound source. The other walls are assumed to be part of the listening room. AkAbak can take into account up to three reflectors: wall, room edge and room corner. The reflection act both on the radiation and on the radiation resistance. The data for the position of the speaker with respect to the walls are saved at the start of the script, in the `Def_Reflector` definition. Each radiator that is involved in the reflection is given the keyword `Reflection` as parameter. The keyword usually follows `WEdge=`, `HEdge=`, etc. which always have to be entered for computing reflections. First enter the keyword `Reflection` for both woofer and tweeter after the entry `WEdge=15cm` and `HEdge=30cm`. Then open the `Def_Reflector` dialog (`Def/ Def_Reflector...` menu). Using this dialog you can shift your speaker in front of a wall or into an edge or corner and rotate it. Take the time to try out the various possibilities. The slider controls adjust the positional angle. The switches decide the basic arrangement. The input boxes determine the distance (perpendicular) of the origin of the baffle coordinates with respect to the particular wall. When you have entered something here, press the 'Repaint' button to draw the changes. Leave the speaker positioned in front of a horizontal room edge ('Horizontal Edge'). The distance to the bottom ('to bottom') is 20cm and to the rear wall ('to top') is 50cm. Set both angles to zero degrees, so that the speaker is flat on the floor and against the rear

wall. Press the 'Copy and close' button and insert the definition at the start of the script. The script now looks like this:

```

Def_Reflector HorizEdge
  Bottom=20.0cm Top=50.0cm HAngle=0 VAngle=0

Def_BassUnit 'B1'
  fs=50Hz Vas=10L
  Qms=1 Qes=0.5 Re=5ohm Le=1mH
  dD=10cm dD1=2cm tD1=1cm fp=2000Hz
  Xms=2mm Vb=10L Qb/fo=0.1

Def_Speaker 'S1'
  dD=2cm tD1=5mm |Convex Dome
  t1=2mm fp=10kHz
  fs=2kHz Mms=0.5g
  Qms=1 Qes=1 Re=5ohm Le=50uH

System 'Bass'
  Coil Node=1=2 L=0.2mH
  Capacitor Node=2=0 C=5uF
  SynthesisInfo
    Passive FirstNode=1 RL=5ohm QL=0
    fo=5kHz vo=1
    {b0=1; a2=1; a1=1.414214; a0=1; }
  |Impedance compensation
  Capacitor Node=2=0 C=20uF Rs=5ohm
  BassUnit 'B11' Def='B1' Node=2=0
  x=0 y=-10cm z=0 HAngle=0 VAngle=0
  WEdge=20cm HEdge=50cm Reflection

System 'High'
  Capacitor Node=1=2 C=5uF
  Coil Node=2=0 L=0.2mH
  SynthesisInfo
    Passive FirstNode=1 RL=5ohm QL=0
    fo=5kHz vo=1
    {b2=1; a2=1; a1=1.414214; a0=1; }
  |Impedance compensation
  Capacitor Node=2=0 C=20uF Rs=10ohm Ls=0.5mH
  Speaker 'S11' Def='S1' Node=2=0
  x=0 y=0 z=0 HAngle=0 VAngle=0
  WEdge=20cm HEdge=50cm Reflection

```

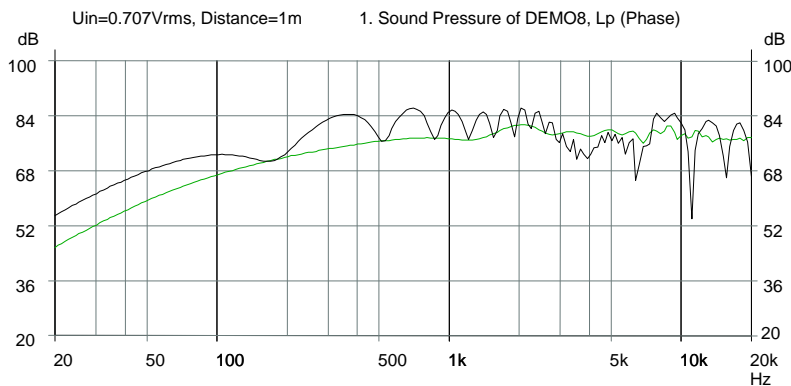

Fig. 14 Sound pressure level curve of the passively filtered system
Rippling curves incl. reflections of a room edge

The reproduction of the sound pressure (Fig. 14) has a great deal of ripple. In reality, the up and down would be somewhat more highly damped, especially in the upper frequency range, since the walls never completely reflect the sound (optional an absorption coefficient can be specified). But the

reflector simulation gives a good impression of the effect of the mounting position on the reproduction.

Time domain transformation

As an example of data-processing in AkAbak let us transform the sound pressure spectrum to the time domain. For this activate the diagram with the sound pressure simulation including the reflections (Fig. 14) and select the legend of the first graph. Then issue 'Calc/ Spectrum to time...'. At the 'Abscissa range' check '0...1' and press 'Ok'. In the time domain diagram zoom out the abscissa range of approx. 0...5ms as displayed in Fig. 15. Since AkAbak removes the time delay due to the distance from the origin to the listening point (here 1m) the impulse response starts at $t=0$ since the tweeter is located at (0,0). On the other hand, the woofer is vertically dislocated and involves radiation from a cone. Hence the impulse response is a cascade of impulses. Further added are the delayed reflections due to diffraction at the enclosure edges. At $t=3\text{ms}$ there is another late impulse which is produced by the reflecting walls.

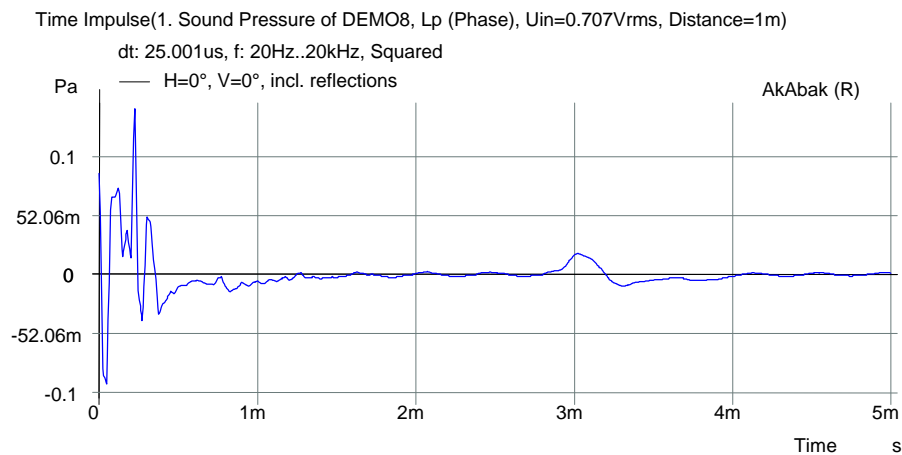

Fig. 15 Time domain response of sound pressure incl. reflections

